

LAGGING FOR PLASTIC MODULAR BELTS

Lagging based on the specification of plastic modular belt manufacturers

Product Description

- Applications**
- ✓ Food and hygienic applications
 - ✓ For driving most common plastic modular belts
 - ✓ For Motors for applications with positive drive belts or no belts
 - ✓ For standard asynchronous drum motors with frequency inverter. The frequency inverter should be set up to reduce the power by 18 %.
 - ✓ For synchronous drum motors (see p 82)

Note: Where possible, avoid using 8 and 12 pole motors with rubber lagging as they can reach high operating temperatures and may cause thermal overload. For further advice please contact your Interroll customer consultant.

- Characteristics**
- ✓ Resistant to abrasion
 - ✓ Quiet operation
 - ✓ Reduced wear on belt
 - ✓ Easy to clean
 - ✓ High resistance to oil, fat and chemicals

Note: Lagging has an influence on the outer diameter of the drum motor and on the velocity. The belt pull and speed of the drum motor must be recalculated according to the increased diameter. Refer to the velocity factor (VF) in the table below.

Technical Data

Material	Hot vulcanised NBR
Temperature range	-40 to +120 °C
Shore hardness	70 ± 5 Shore A
Colours	White / Blue
Approvals	FDA / EC 1935/2004

Product Range

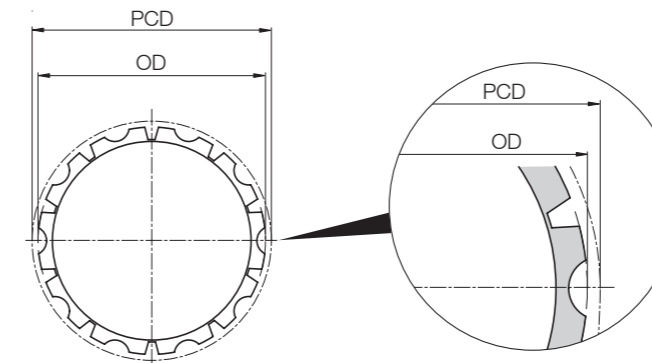

- Z Number of teeth
- OD Outer diameter in mm
- PCD Pitch circle diameter in mm
- VF Velocity factor

Plastic modular belt manufacturer	Series	Lagging 80D oil-free				113i / 113D				138i				165i				217i					
		Z	OD mm	PCD mm	VF	Z	OD mm	PCD mm	VF	Z	OD mm	PCD mm	VF	Z	OD mm	PCD mm	VF	Z	OD mm	PCD mm	VF		
Ammeraal Beltech / Uni-Chains	HDS60500	24	98.5	97.3	1.21	32	131.0	129.6	1.14	38	155.2	153.8	1.11										
	HDS61000	12	99.0	98.1	1.22	16	132.0	130.2	1.15	19	156.6	154.3	1.12										
	HDS62000	7	110.8	114.1	1.42	9	144.2	146.2	1.29	10	160.5	161.8	1.17	12	193.0	193.3	1.18						
	CNB	12	98.0	98.5	1.22	16	131.0	130.7	1.15	19	155.5	154.9	1.12										
	MPB	7	105.5	117.1	1.45	9	140.0	148.5	1.31	10	156.6	164.4	1.19	12	190.0	196.3	1.20	15	239.0	244.3	1.12		
	OPB-4					9	144.0	146.2	1.29	10	160.0	161.8	1.17										
	OPB-8					9	139.5	146.2	1.29	10	155.5	161.8	1.17										
	S-MPB	12	97.9	100.1	1.24	16	132.0	132.3	1.17	20	165.0	164.9	1.19	24	198.0	199.0	1.21						
	UNI QNB					16	131.2	130.7	1.15														
	X-MPB					8	152.0	165.9	1.46														
Eurobelt	B50									10	154.0	161.8	1.17	12	187.0	193.2	1.18						



Options
Lagging for
Plastic Modular
Belts

LAGGING FOR PLASTIC MODULAR BELTS

Lagging based on the specification of plastic modular belt manufacturers

Plastic modular belt manufacturer	Series	Lagging 80D oil-free				113i / 113D				138i				165i				217I				
		Z	OD mm	PCD mm	VF	Z	OD mm	PCD mm	VF	Z	OD mm	PCD mm	VF	Z	OD mm	PCD mm	VF	Z	OD mm	PCD mm	VF	
Habasit																						
	M1200 PE/AC	24	92.5	97.3	1.21	32	125.0	129.6	1.14		38	149.5	153.8	1.11								
	M1200 PP	24	96.0	101.0	1.25	32	128.0	132.6	1.17		38	154.0	158.6	1.15								
	M2500	12	99.4	99.0	1.23	16	132.8	131.6	1.16		20	165.0	163.5	1.18	23	190.5	189.7	1.16				
	M5000					9	140.0	149.0	1.31		10	156.6	164.4	1.19	12	190.5	197.2	1.20				
Intralox																						
	800	7	105.5	116.5	1.45	9	140.1	148.5	1.31		10	156.8	164.4	1.19	12	190.0	196.3	1.20	15	239.0	244.3	1.12
	850					9	143.6	148.5	1.31					12	187.0	196.3	1.20					
	1600	13	105.8	105.8	1.31	16	130.5	130.2	1.15		20	163.0	162.4	1.18	23	187.4	186.5	1.14	30	244.3	243.0	1.12
	1650	13	104.9	105.8	1.31	16	129.3	130.2	1.15		20	162.0	162.4	1.18	23	186.3	186.4	1.14				
	1800					8	152.0	165.9	1.46		9	174.0	185.7	1.35								
	1100 FG PE/AC	20	91.0	98.9	1.23	26	120.6	128.4	1.13		32	150.0	157.8	1.14								
	1100 FG PP	20	91.5	99.5	1.24	26	121.4	129.1	1.14		32	151.0	158.8	1.15								
	1100 FT PE/AC	20	93.5	97.3	1.21	27	128.0	131.0	1.15		32	152.6	156.00	1.13								
	1100 FT PP	20	94.0	98.3	1.22	26	124.0	127.6	1.12		32	153.0	156.9	1.14	38	184.0	186.2	1.14				
Rexnord																						
	1010	12	97.5	98.1	1.22	16	130.0	130.2	1.15													
	2010					9	138.8	147.9	1.30		10	156.8	165.0	1.20								
Scanbelt																						
	S.25-100 & 600	12	92.2	98.7	1.23	16	123.0	128.2	1.13		19	146.5	151.9	1.10								
	S.25-800	12	93.6	96.8	1.20	16	125.8	128.3	1.13		20	157.8	159.8	1.16								
	S.50-100 & 600					9	131.2	146.8	1.29		11	164.5	178.2	1.29	12	179.0	193.0	1.18	16	244.0	256.3	1.18
	S.50-800					9	136.0	146.2	1.29		10	155.2	163.9	1.19	12	185.0	193.2	1.18	15	233.5	240.5	1.11
	S.50-801					9	138.0	139.0	1.22		10	155.0	164.0	1.19	12	185.0	195.6	1.19				
Forbo-Siegling																						
	LM14 Series 4	21	93.0	95.3	1.18																	
	LM25 Series 2	13	107.0	107.0	1.33	16	131.5	131.5	1.16													
	LM50 Series 3					9	140.0	146.2	1.29		10	157.0	161.8	1.17	12	189.0	193.2	1.18	16	251.5	256.3	1.18
	LM50 Series 6	7	107.5	116.2	1.44	9	137.5	146.2	1.29		11	170.6	180.0	1.30	13	205.0	208.9	1.27				

If you didn't find your belt type or belt supplier please see updated list on www.interroll.com